

# Automated Multi-Pipe Slip Type (AMS) Elevator

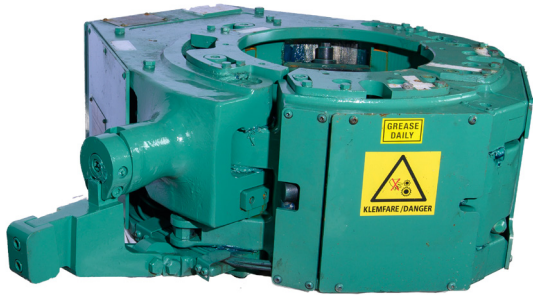

AMS-125

The elevator allows any slick joint to be handled from horizontal to vertical without the use of lift nubbins or lift plugs.

The AMS hooks up on the same hoses for the standard BXS elevator. If the rig can't accommodate that, the elevator can be used with a control panel.

## KEY FEATURES

- Load Rating: 125 sTon
- Size Range: 7 3/4" → 17"
- Fits in 350 ton and 500 ton bails
- Hydraulic feedback signal when doors are closed
- Rotor system enabling pick up from horizontal to vertical position
- Manufactured in accordance with API 8C
- Hydraulically actuated opening/closing system
- Hydraulically actuated slip movement
- One Frame for different pipe types (upset and non-upset) and ranges with interchangeable slip system
- Visual feedback when doors are closed
- Interlock to prevent unintended opening
- Hydraulic rotation system to enable pick up pipes from horizontal position
- Weight(w/o slips)[kg]: 1400
- Dimension(LxWxH)[mm]: 1228.5x1562x490

3 Options for control

- Radio remote
- Driller chair control
- Hydraulic control panel

## COMPONENTS

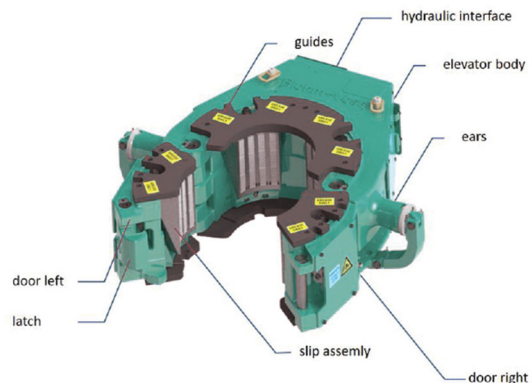

## ABC DIMENSIONS

